

# AIR INTAKE RELOCATION KIT INSTRUCTION



## Before you begin

1. Read these instructions and check to be sure all parts and tools are accounted for.

## Important

1. Our product is a unique design for your vehicle.
2. Please read the installation instructions carefully before you start.
3. If the vehicle is clean and free of other debris, it will be easy to install.
4. For your safety and to ensure a satisfactory installation, please complete all the installation steps in the order shown below.

## Product

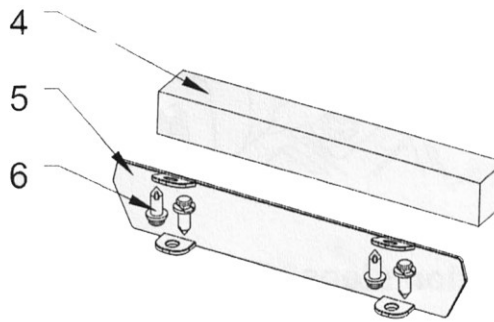
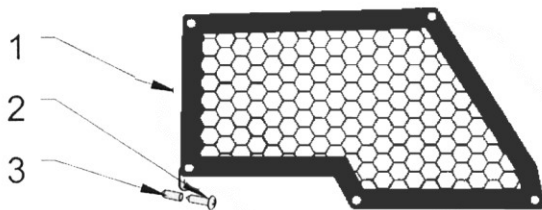

## Product content

REF	QTY	PART DESCRIPTION
1	1	air relocation grill
2	6	Self-tapping screws
3	6	Rubber cap
4	1	Sound insulating foam
5	1	Intake block off plate
6	4	Push rivet clip

## Tools required

- \*DRILL
- \*DREMEL
- \*TORX SCREW DRIVE
- \* 5/16 DRILL BIT

## Intake block off plate installation steps:

1. Remove the rear box cover and insert sound insulating foam from the back of the body.

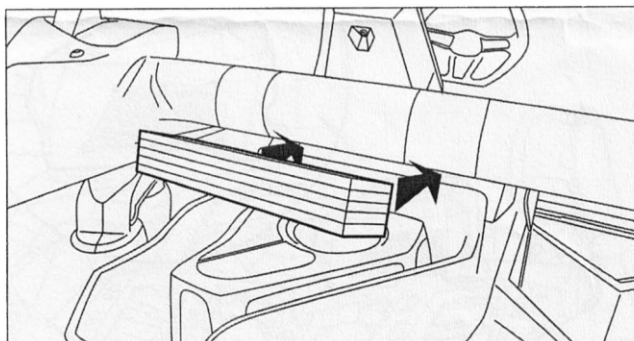

2. Put the Intake Block Off Plate in place behind your seat, mark the four mounting holes.

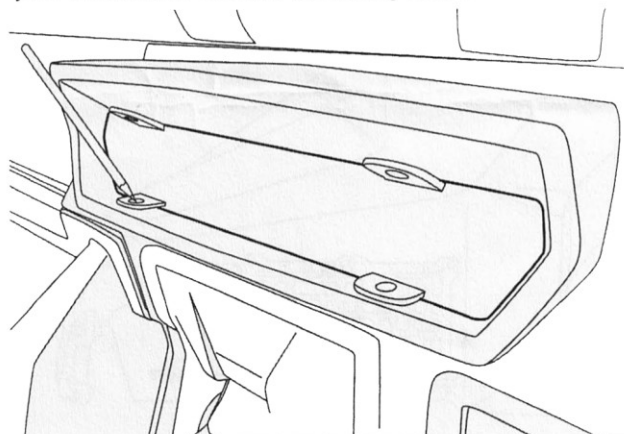

# AIR INTAKE RELOCATION KIT INSTRUCTION

3. Use electric drill to drill four mounting holes.  
\*\*Use plate to make holes and remove plate  
to drill out the 4 holes

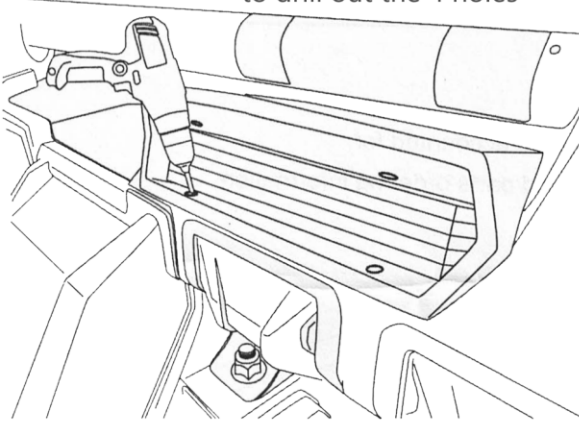

4. Use the push rivet clips to install the Intake Block Off Plate.

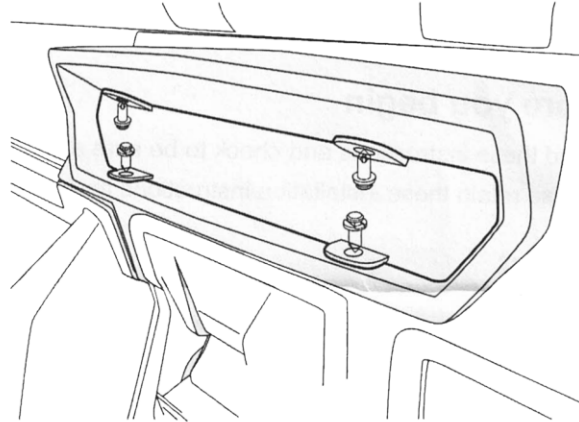

## Installation steps of grid ventilation window:

1. Cut out the template and stick it on your rear intake cap.  
\*\*Take your time measure 3 times cut once.

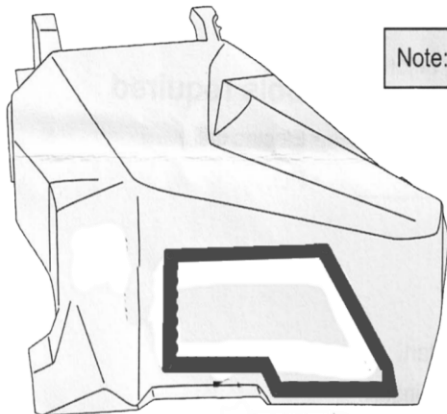

Note: Template is included

2. Put on the rear air relocation grill, fix it with the self-tapping screws.

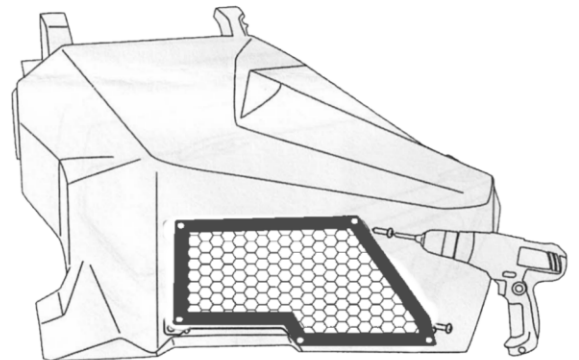

3. Put on the rubber bolt caps to protect the self-tapping screws. Put back the rear intake cap to your x3, installation complete.

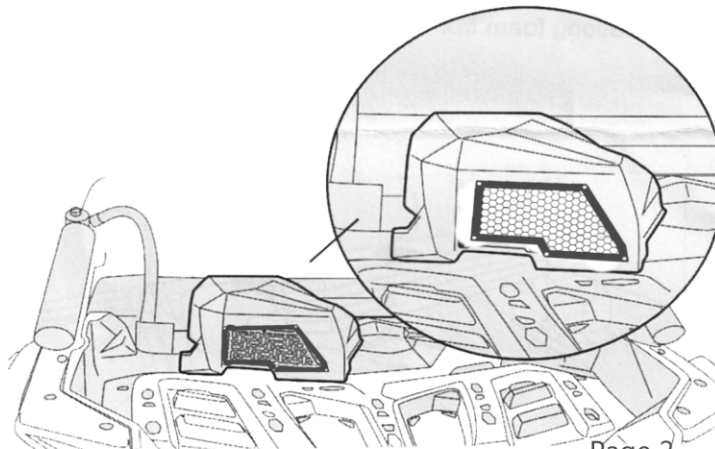



# TEMPLATE

**Patent Pending**

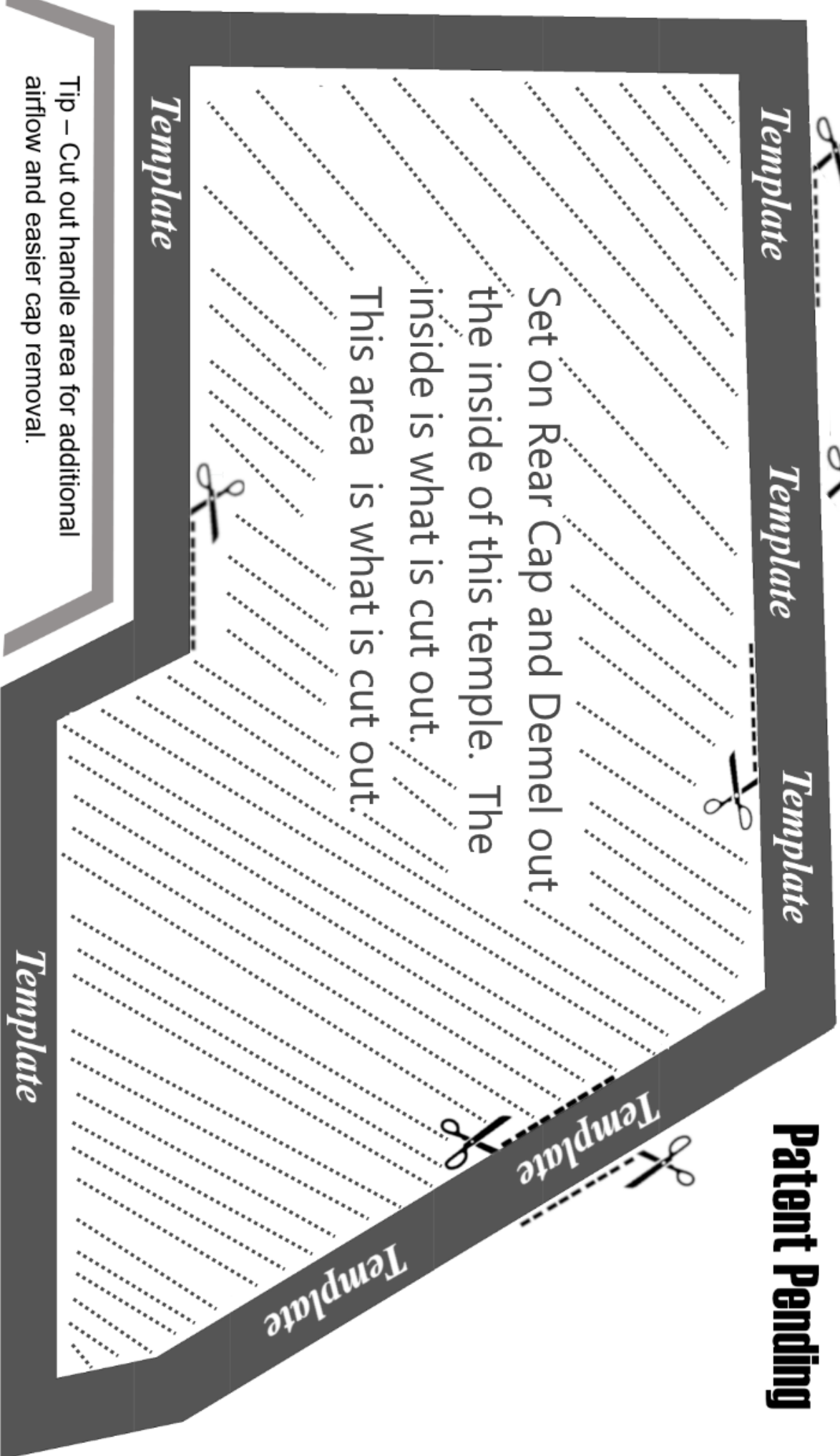

Set on Rear Cap and Demel out  
the inside of this temple. The  
inside is what is cut out.  
This area is what is cut out.

Tip – Cut out handle area for additional  
airflow and easier cap removal.